

CHECKERED RACING

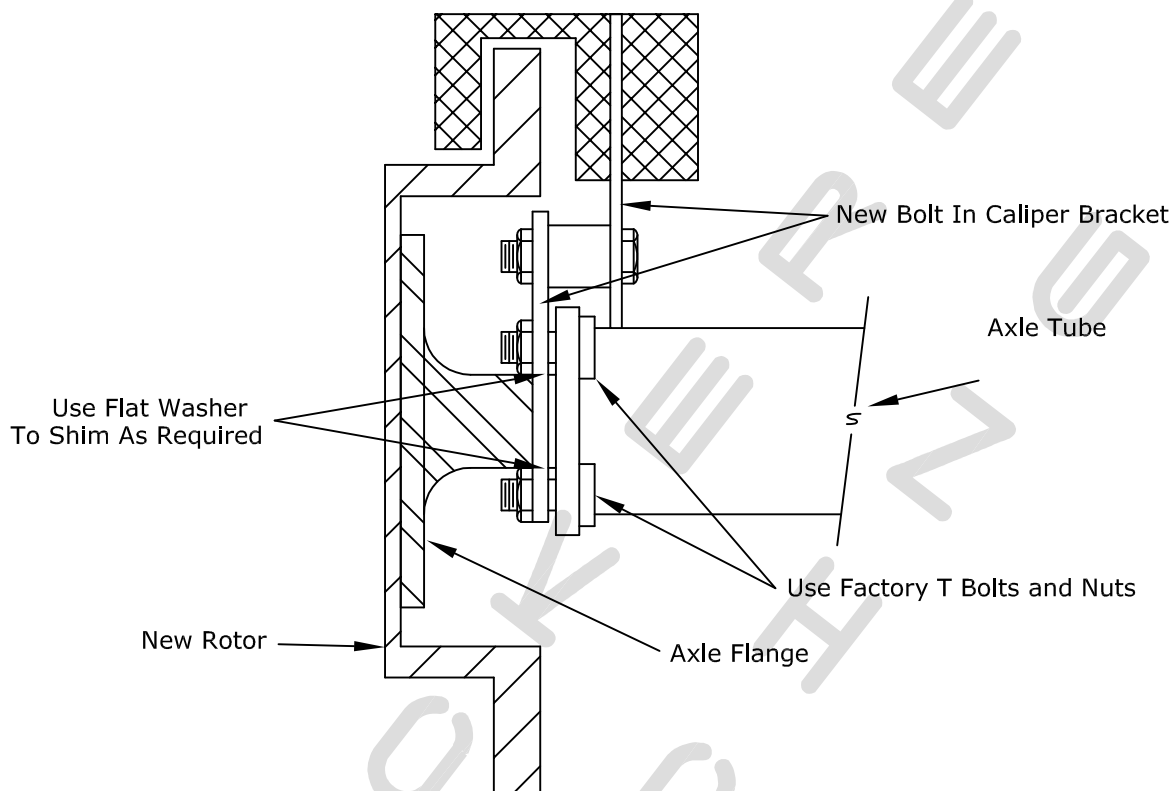

Instructions

- 1) Remove The Rear Axle.
- 2) Discard The Backing Plate and Stock Retainer Plate.
- 3) Reinstall The Axle.
- 4) Install The New Caliper Bracket Using The Factory "T" Bolts and Nuts. Using Lock Washers Shim Between The New Caliper Bracket and The Housing End. Make The Axle Bearing Is Tight. This Bracket Holds Your Axle In The Rear End Housing.
- 5) Install The New Rotor Over The Axle Flange.
- 6) Install The Caliper With Caliper Bolts Provided. Make Sure The Bleeder Is Up and The Line Is To The Inside Of The Car.
- 7) Check All Bolt, Repeat On Other Side And Bleed The Brakes.